

Pinewood Derby Construction Steps

1. **Design the Car** - Design on paper first.
2. **Shape the Car** - Band saw, coping saw, sanding usually work best. (Do not make car so thin that added molten weight will burn through the body.)
3. **Add Weight** - Car weight can't exceed 5 oz. If you are melting lead, it is a good idea to add weight BEFORE painting the car. **We will have everything for adding weight to the cars at the work days and test day.**
4. **Paint the Car** - Spray paint works best. (We have a LIMITED amount of colors and paint at the work days. If the boys want something specific they need to bring their own paint to the work days.)
5. **Mount Wheels** - The wheels should be square with the car and spin freely. The only lubricant allowed this year is powdered graphite.

When complete -

DON'T PLAY WITH THE CAR!

**CAR DESIGNS, BUILDING TIPS, HELPFUL HINTS, ETC.
ARE AVAILABLE ON THE GROUP WEBSITE.**

Go to www.2047.org select **Stockade or Derby**

There is no live webcast of the derby this year.
This will be back next year.

If you have any questions, need replacement parts or require assistance call or text **Jim at 536-4077** or jim@2047.org email

Sign up for Derby Work Days via our website @ www.2047.org
We will keep parents informed via our Facebook page (csb2047) ,
Text Message and our webpage (2047.org).

Derby Kit Cost: \$10. Can be paid at Stockade or
on our website (2047.org, left hand side of main page)

Derby Car Help Days

(Stockade Cadets, dad's and adults welcome)

Saturday, January 11, 11-2

Saturday, January 25, 11-2

(also available to help boys other times -
contact Jim to schedule)

Derby Test Day

Sat, February 1 - 11am - 2pm

Car Due Day

Wednesday, February 5th @ Stockade

WEDNESDAY, FEBRUARY 12 RACE DAY

STOCKADE CADETS

Everyone is invited!

Derby Regional Race

for the top racers from our Stockade

Saturday, March 8 @ 9am

Crossroads Church

1050 Girdle Rd, East Aurora, NY 14052

Derby Rules

1. This is a "fun" event. We make cars, we race, we eat junk food. Don't stress.
2. All racers must be active registered members of our group.
3. **Car width and overall length shall not exceed 7" long x 3" wide including wheels, axles and attachments. Minimum bottom clearance between car and track is 3/8".** No part of the car may extend beyond the starting gate. (Indented car noses are prohibited.) Any attachments must fit through the finish line at our race and regional finals.
4. Car kit must be purchased from Stockade this year and built for this year's race.
5. Only wheels and axles from the official kit can be used and they must be inserted in the provided slots.
6. Car weight can not exceed 5oz. (142 grams).
7. Details such as steering wheel, driver, decals and painting are encouraged as long as these details are securely attached to the car and these details do not cause the car to exceed legal car weight and dimensional specifications.
8. Wheels and axles may be lightly filed, sanded and/or polished to smooth and true them, however original wheel diameter and width must be reasonably maintained and the wheels must remain flat. Wheel's cannot be filled with weight, tapped, or altered except as stated above.
9. A maximum of 2 washers per wheel are allowed and can be purchased at a hardware store. Bearings, bushings, springs, and propulsion devices are prohibited.
10. Stockader's name should be written on the bottom of the car. Cars will be numbered at Stockade prior to the race. There should be no numbers on the car when handed in.
11. Cars with wet paint or missing wheels will not be accepted.
12. **NOTE: The "Regional" races are only allowing graphite for lubrication this year.**

A Test day will be held prior to the cars being due. This is the ONLY time weight and scales will be available to test the cars. Test day will allow the Stockader's to test run, and add weight to their car. parents are welcome to est and work days and we will have all the supplies required.

Car due day for the Pinewood Derby will occur a week before the race. All competing cars must be submitted at this time. Cars will be carefully inspected, measured and weighed to ensure that they meet the rules regarding car construction. Car weight may be adjusted by the owner at registration, scales and a hand drill will be available. Cars which do not pass inspection will not be accepted. The Chairman may, at his discretion, allow cars which fail inspection to be resubmitted after being brought promptly into conformance with the

Remember, this is a "fun" event!

The boys get to learn how to use tools, play with some paint and enjoy the time planning and making his car . It's important for the boys to learn how to compete but also important for them to have some fun too. In our races the competition really is secondary to the making of the car and race day. We make cars, we race. Some kids win and some not so much. We have some brownies, give out trophies and then plan for next year!

DERBY CAR TEMPLATE

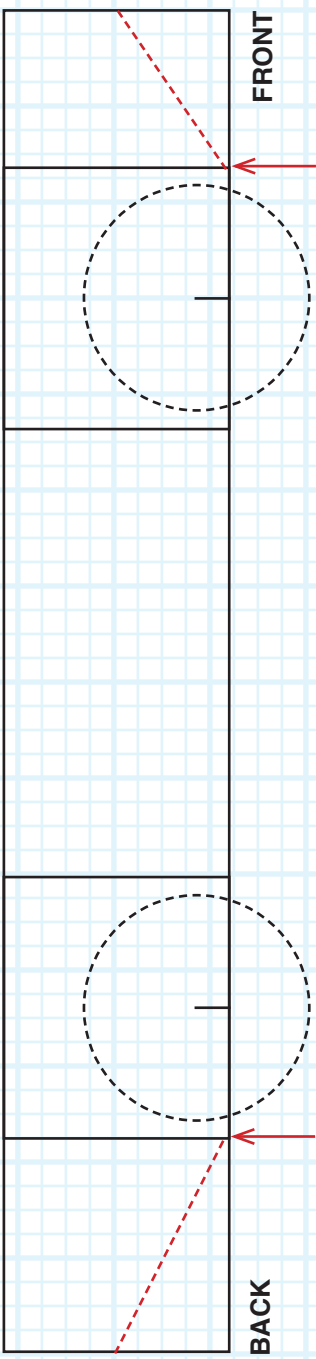

Note: if your car is going to race on the "Loop" it must be trimmed on the red dotted line

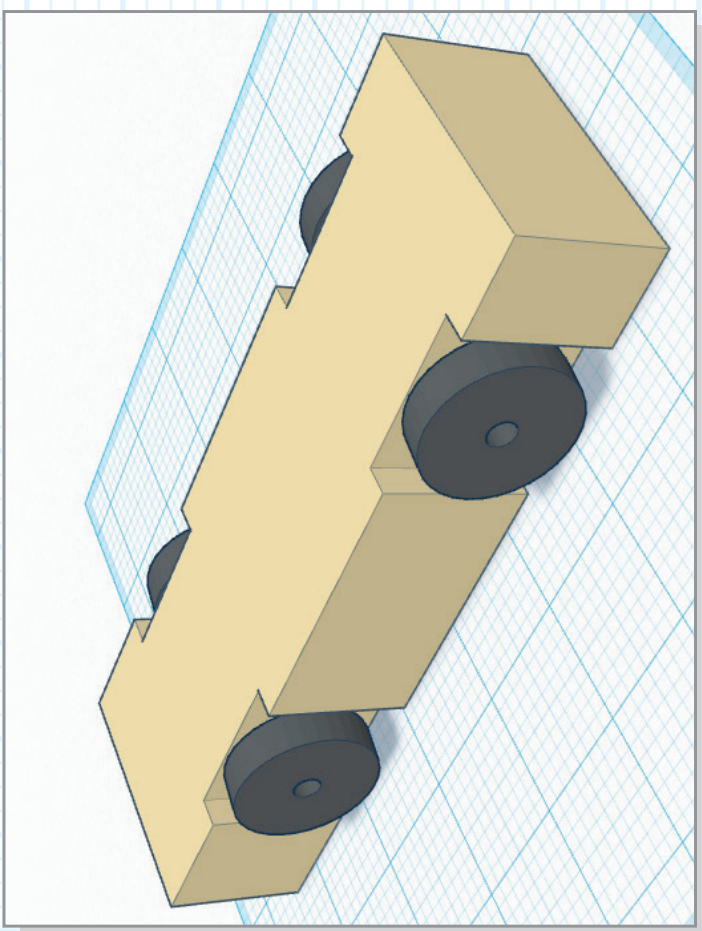
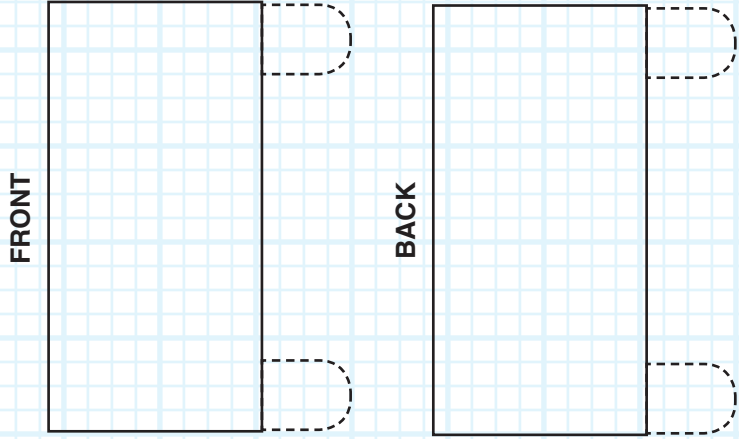
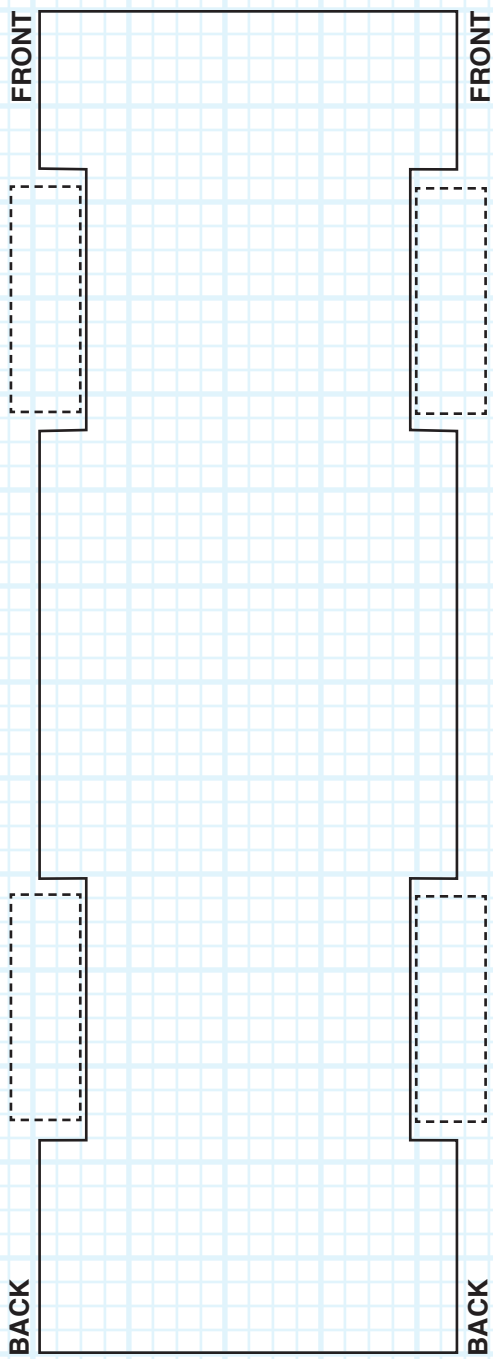

Notes: